

番号	登録品番	T1	T2(PT)
1	7011-6	U9/16	R1/4
2	7011-9	U11/16	R3/8
3	7011-12	U13/16	R1/2
4	7011-15-12PT	U1"	R1/2
5	7011-15-19PT	U1"	R3/4
6	7011-19	U1"3/16	R3/4
7	7011-25	U1"7/16	R1"
8	7011-32	U1"11/16	R1"1/4

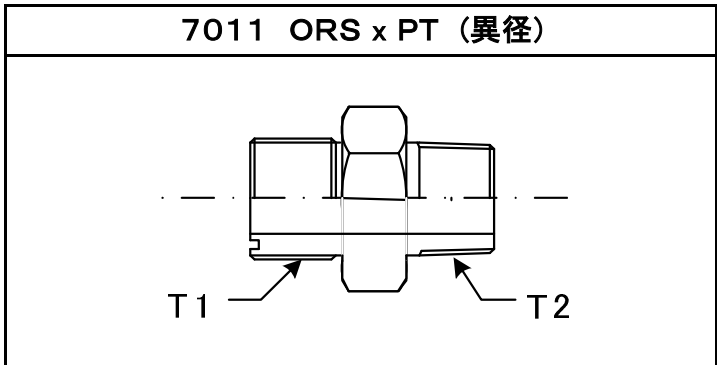

<備考>
ORS(オス)×PTねじ(オス)

YH:7011
BS:



番号	登録品番	T1	T2(PT)
	<PT側大>		
1	7011-6-9PT	U9/16	R3/8
2	7011-9-12PT	U11/16	R1/2
3	7011-12-19PT	U13/16	R3/4
4	7011-19-25PT	U1"3/16	R1"
5	7011-25-32PT	U1"7/16	R1"1/4
	<PT側小>		
6	7011-9-6PT	U11/16	R1/4
7	7011-12-9PT	U13/16	R3/8
8	7011-19-12PT	U1"3/16	R1/2
9	7011-25-19PT	U1"7/16	R3/4

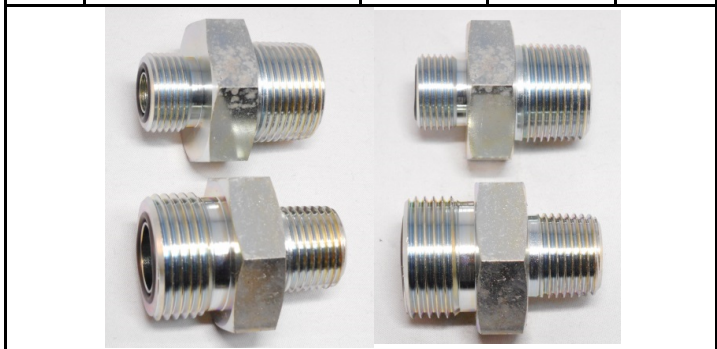

<備考>
ORS(オス)×PTねじ(オス) 異径

YH:7011
BS:

数は少ないですが、在庫しています。

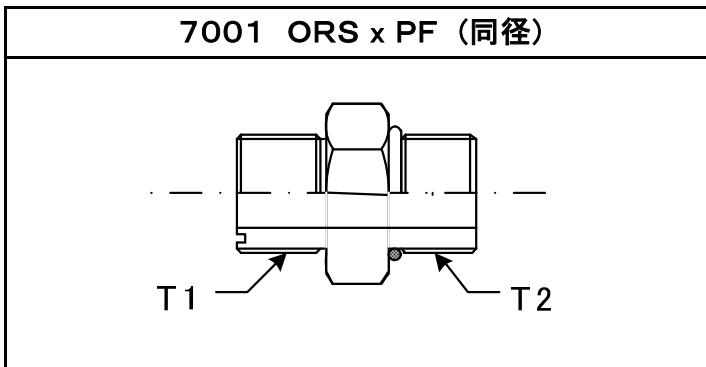

番号	登録品番	T1	T2(PF)
1	7001-6	U9/16	G1/4
2	7001-9	U11/16	G3/8
3	7001-12	U13/16	G1/2
4	7001-15-12	U1"	G1/2
5	7001-15-19	U1"	G3/4
6	7001-19	U1"3/16	G3/4
7	7001-25	U1"7/16	G1"
8	7001-32	U1"11/16	G1"1/4

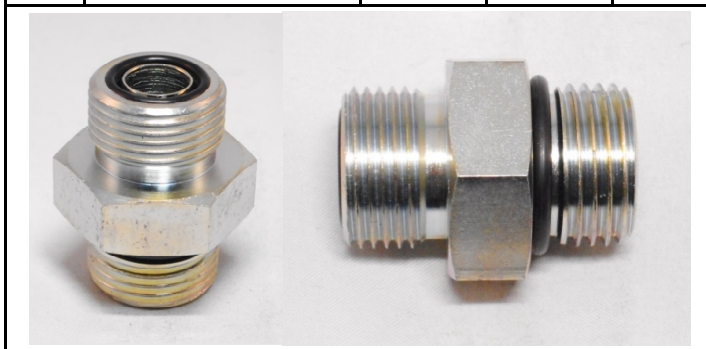

<備考>
ORS(オス) x PFねじ(オス)(Oリング)
Oリング付きORSアダプター
YH: 7001
BS:

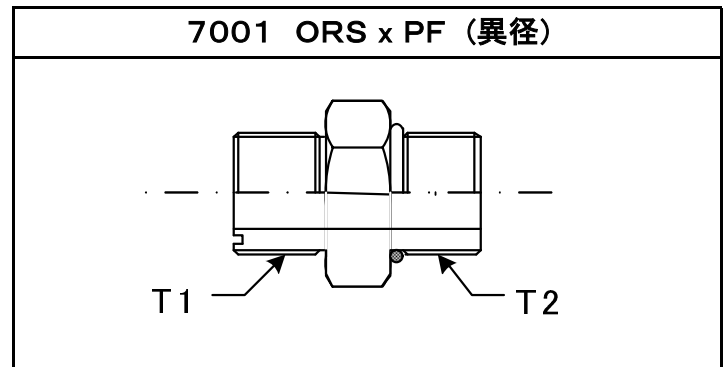

番号	登録品番	T1	T2(PF)
<Oリング側大>			
1	7001-6-9	U9/16	G3/8
2	7001-9-12	U11/16	G1/2
3	7001-12-19	U13/16	G3/4
4	7001-19-25	U1"3/16	G1"
<Oリング側小>			
5	7001-9-6	U11/16	G1/4
6	7001-12-9	U13/16	G3/8
7	7001-19-12	U1"3/16	G1/2
8	7001-25-19	U1"7/16	G3/4

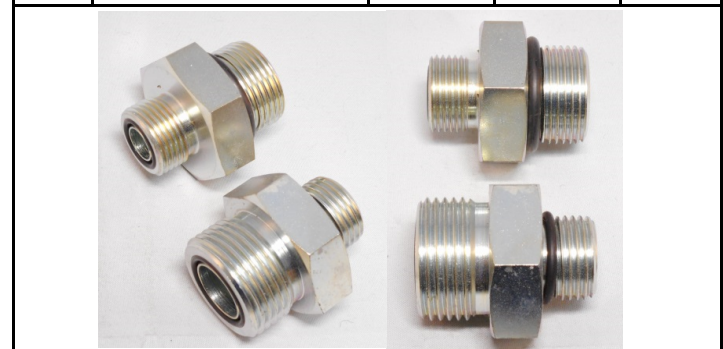

<備考>
ORS(オス) x PFねじ(オス)(Oリング) 異径
Oリング付きORSアダプター
YH: 7001
BS:

